

60EJB60243600 Series

(24VDC STANDARD)

OUTPUT POWER: 27W(APPROX)

WEIGHT: 1200~1500g(APPROX)

Typical applications: Massage Equipment, welding feed, andiron, washing machine, aeromodelling, fiber optic fusion splicers, OA equipment, amusement equipment, ATM bank automated system.

MOTOR CHARACTERISTICS

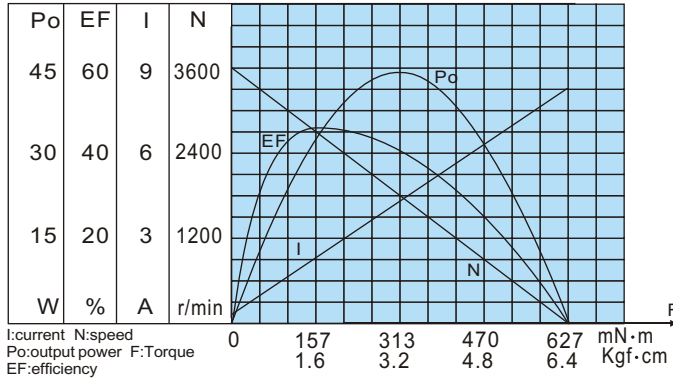

MOTOR TORQUE/SPEED/CURRENT

Rated voltage	24VDC
No load speed	3600r/min
No load current	500mA
Rated torque	1600gf·cm 157.4mN·m
Rated current	2A
Rated speed	2700r/min
Stall torque	7200gf·cm 706mN·m
Stall current	8A

APPEARANCE SIZE

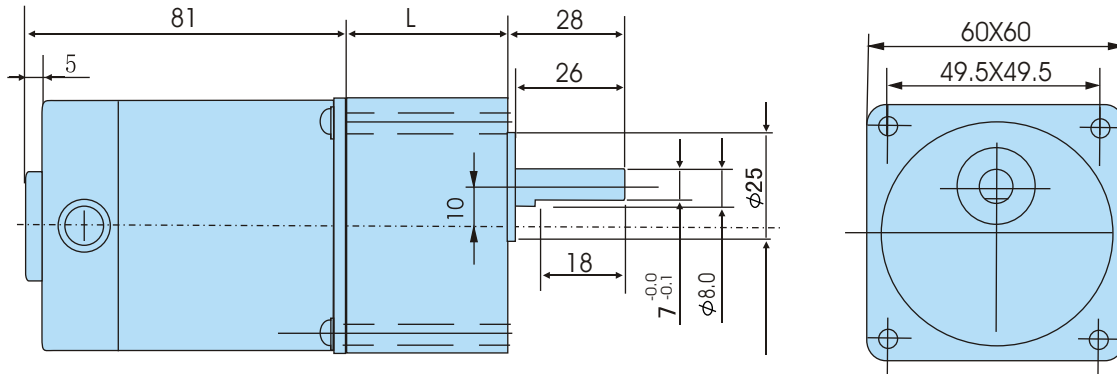

GEARED MOTOR TORQUE/SPEED/CURRENT

Geared motor name	Rated Volt V	No load		Load torque				At maximum efficienc		Output pwer W	Number of gear trains	Gearbox length "L" mm
		Current mA	Speed r/min	Current A	Speed r/min	Torque		Kgf·cm	N·m			
						Kgf·cm	N·m					
60EJB60243600-3.2K	24	≤ 500	1125	≤ 2.0	845	4.2	0.31	10	0.98	36	2	28.5
60EJB60243600-7.2K	24	≤ 500	500	≤ 2.0	375	9.6	0.71	22	2.16	36	2	28.5
60EJB60243600-10K	24	≤ 500	360	≤ 2.0	270	13	0.98	30	2.94	36	2	28.5
60EJB60243600-20K	24	≤ 500	180	≤ 2.0	135	27	1.96	60	5.88	36	2	28.5
60EJB60243600-30K	24	≤ 500	120	≤ 2.0	90	35.5	2.65	80	7.84	32	3	28.5
60EJB60243600-40K	24	≤ 500	90	≤ 2.0	68	47	3.43	100	9.8	32	3	28.5
60EJB60243600-60K	24	≤ 500	60	≤ 2.0	47	60	5.88	180	17.64	28	3	28.5
60EJB60243600-90K	24	≤ 500	40	≤ 1.7	33	60	5.88	180	17.64	20	4	38.5
60EJB60243600-120K	24	≤ 500	30	≤ 1.4	26.5	60	5.88	180	17.64	16	4	38.5
60EJB60243600-180K	24	≤ 500	20	≤ 1.0	18.4	60	5.88	180	17.64	11	4	38.5
Other Ratio	1:4.8(750r/min), 1:13.3(270r/min), 1:270(13.3r/min), 1:360(10r/min), 1:510(7r/min)											
Packing Details	CTN size: 28X17.5X13CM				8pcs/CTN N.W. 12Kgs							