



ETG-38127000 Series

(12VDC STANDARD)

OUTPUT POWER: 2.5W(APPROX)

WEIGHT: 180~200g(APPROX)

Typical applications: Labal printers, auto shutter, welding machines, water meter IC card, grill, oven, cleaning machine, garbage disposers, household appliances, slot machines, money detector, automatic actuator, coffee machine, towel disposal, lighting, coin refund devices, peristaltic pump.

MOTOR CHARACTERISTICS

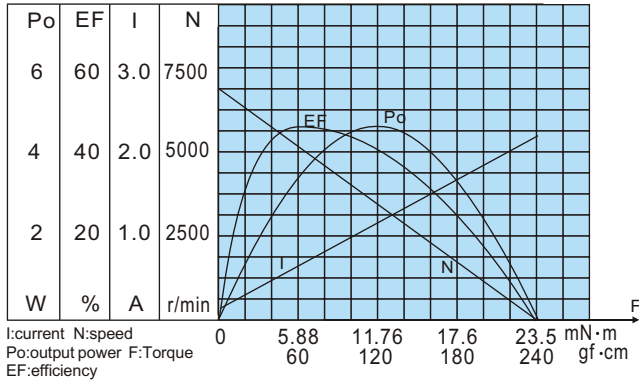

MOTOR TORQUE/SPEED/CURRENT

Rated voltage	12VDC
No load speed	7000r/min
No load current	70mA
Rated torque	60gf · cm 5.88mN · m
Rated current	410mA
Rated speed	5200r/min
Stall torque	240gf · cm 23.5mN · m
Stall current	1.8A

APPEARANCE SIZE

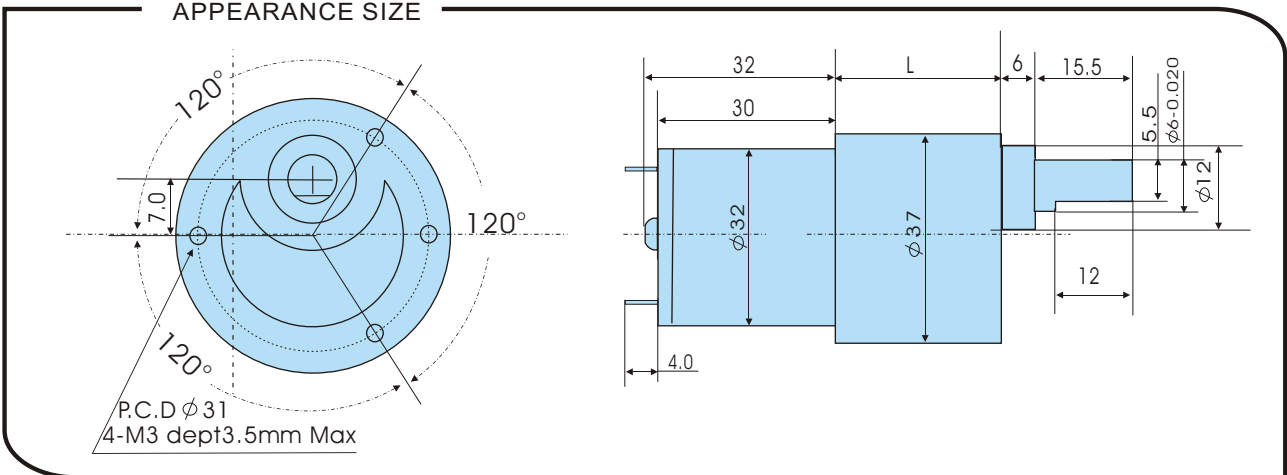

GEARED MOTOR TORQUE/SPEED/CURRENT

Geared motor name	Rated Volt. V	No load		Load torque				At maximum efficiency		Output power W	Number of gear trains	Gearbox length "L" mm
		Current mA	Speed r/min	Current mA	Speed r/min	Torque		Kgf · cm	N · m			
						Kgf · cm	N · m					
ETG-38127000-6K	12	≤70	1160	≤410	860	0.29	0.03	1.0	0.1	2.5	2	22
ETG-38127000-10K	12	≤70	700	≤410	520	0.49	0.05	1.5	0.15	2.5	2	22
ETG-38127000-20K	12	≤70	350	≤410	260	0.88	0.09	3.0	0.29	2.3	3	22
ETG-38127000-30K	12	≤70	230	≤410	170	1.31	0.13	4.0	0.39	2.3	3	22
ETG-38127000-60K	12	≤70	115	≤410	85	2.38	0.23	7.0	0.69	2.0	4	25
ETG-38127000-90K	12	≤70	77	≤410	57	3.56	0.35	12	1.18	2.0	4	25
ETG-38127000-180K	12	≤70	38	≤410	29	6.37	0.62	19	1.86	1.8	5	27
ETG-38127000-270K	12	≤70	25	≤300	19	9.56	0.94	30	2.94	1.8	5	27
ETG-38127000-540K	12	≤70	13	≤250	11.5	10	0.98	30	2.94	1.2	6	29
Packing Details	CTN size:37X27XH18CM 60pcs/CTN N.W. 12Kgs											